

**AXOR**<sup>®</sup>

**ARTE INTERIOR** 



# CONCEALED HINGES

FOR INTERIOR DOORS



[axorindustry.com](http://axorindustry.com)

## CONCEALED INTERIOR DOOR HINGES

Concealed interior door hinges ARTE Interior 24/24×120 for timber and MDF doors, with the possibility of adjustment. Maximum door weight for a set of two hinges up to 60 kg. Quantity in the package: 2 pcs.

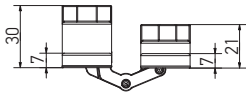
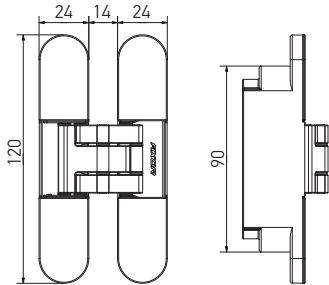

**D5004-00-N01**

White  
RAL 9016



**D5004-00-N03**

Chrome matte



**D5005-00-N01**

White RAL 9016,  
zinc coated



**D5004-00-N05**

Gold



**D5005-00-N03**

Chrome matte,  
zinc coated



**D5004-00-N06**

Bronze



**D5005-00-N07**

Matte black RAL 9005,  
zinc coated



**D5004-00-N07**

Matte black RAL 9005

## CONCEALED INTERIOR DOOR HINGES

Concealed interior door hinges ARTE Interior 30/24×120 for timber and MDF doors, with the possibility of adjustment. Maximum door weight for a set of two hinges up to 60 kg. Quantity in the package: 2 pcs.

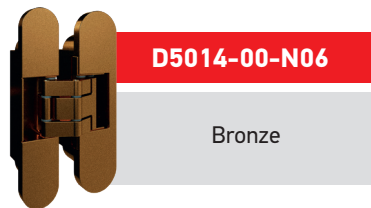
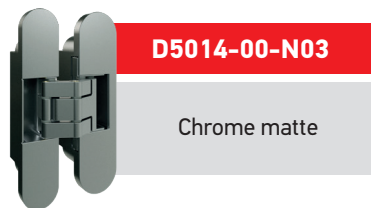
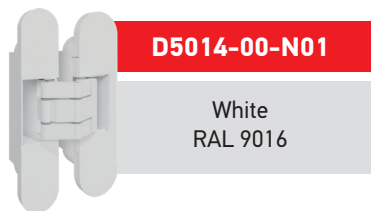
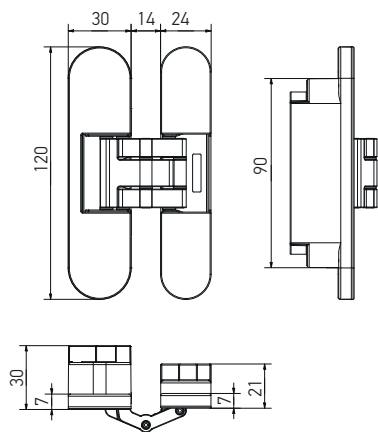

## INSTALLATION OF CONCEALED HINGES (24/24×120)

### CLOSED

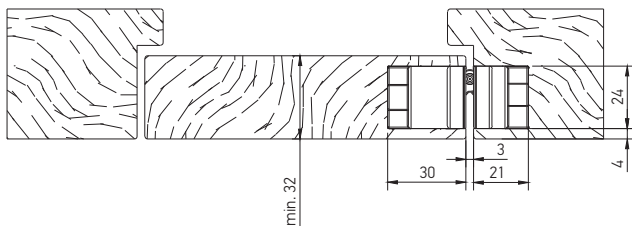

### OPENED 90°

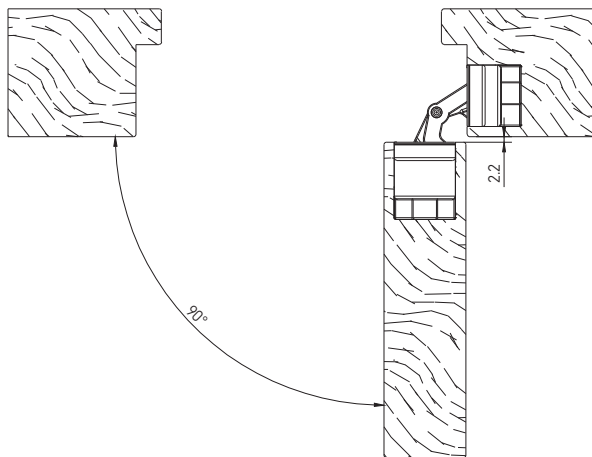

### OPENED 180°

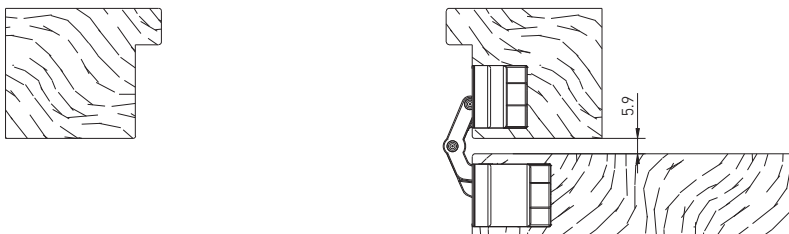

## INSTALLATION OF CONCEALED HINGES (30/24×120)

### CLOSED

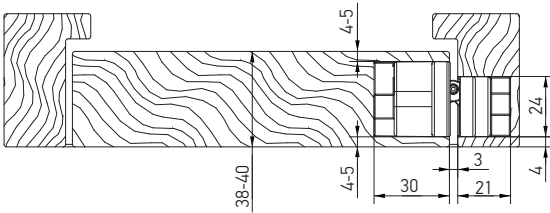

### OPENED 90°

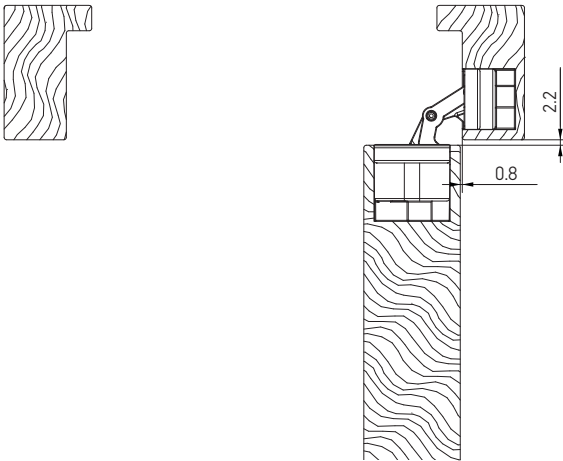

### OPENED 180°

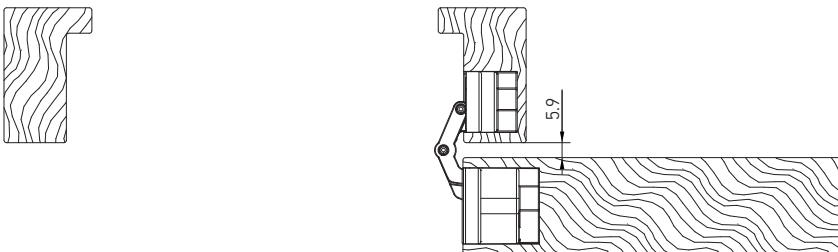



## DIMENSIONS FOR MILLING (30/24×120)

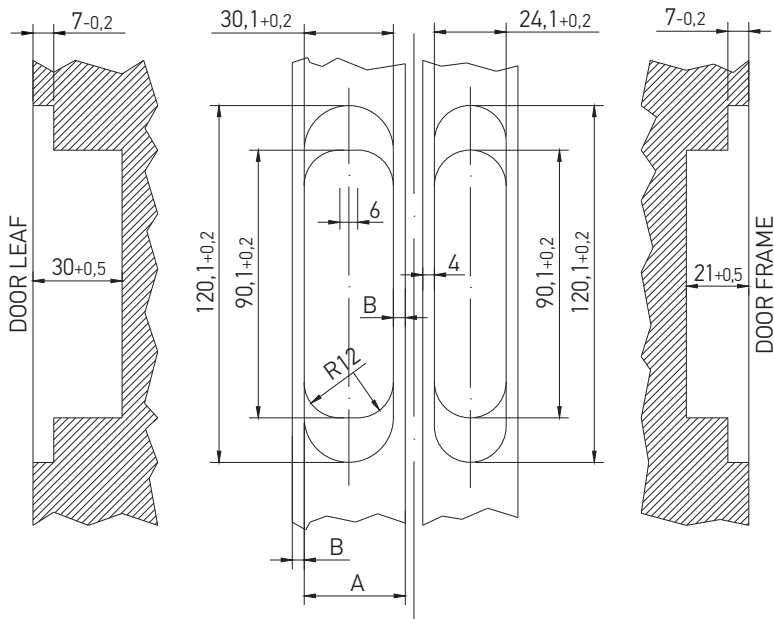

A, mm	B, mm
38	4
40	5

## INSTALLATION SCHEME

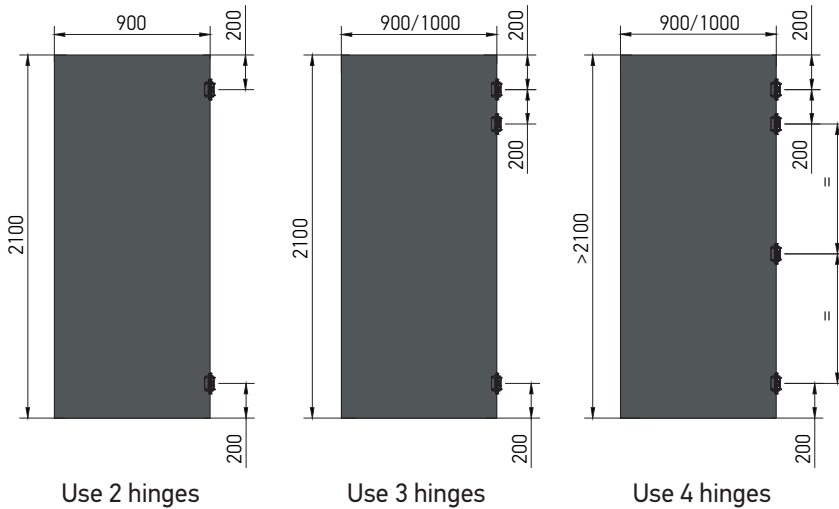

Required number of hinges\*, pcs

	>2100	4	4	4	4	4
Door height, mm	2100	2	2	2	2	3
	2000	2	2	2	2	3
	1900	2	2	2	2	3
	1800	2	2	2	2	3
			600	700	800	900
		Door width, mm				

\* Door weight up to 60 kg



## MILLING PROCEDURE (24/24×120)

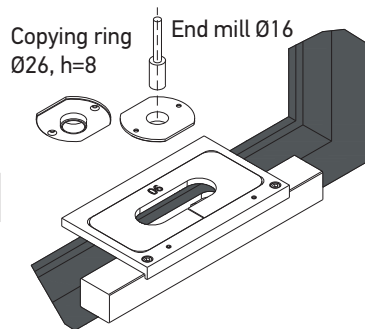
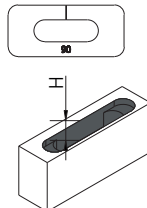
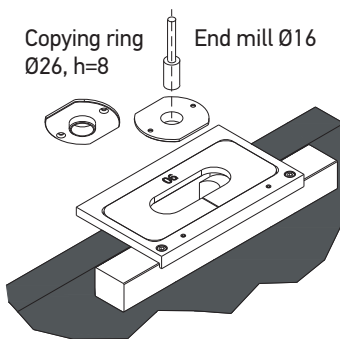
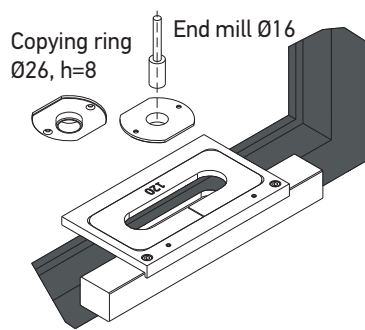
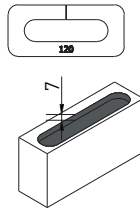
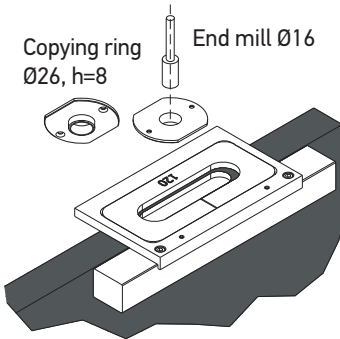
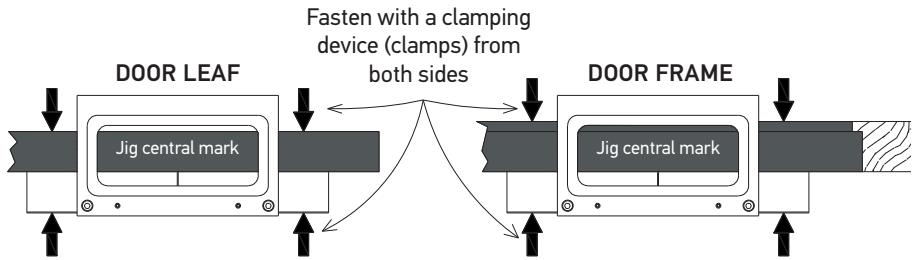

H, mm	
Door leaf	Door frame
30	21

A7226-00-N03 - milling jig 24 mm

## MILLING PROCEDURE (30/24×120)

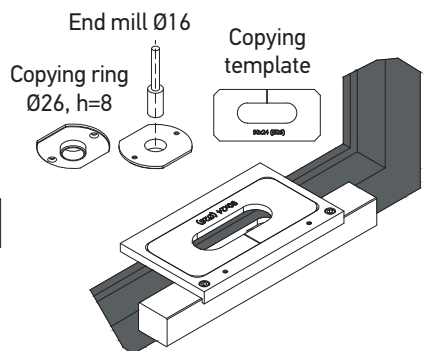
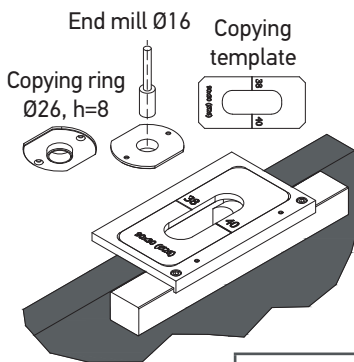
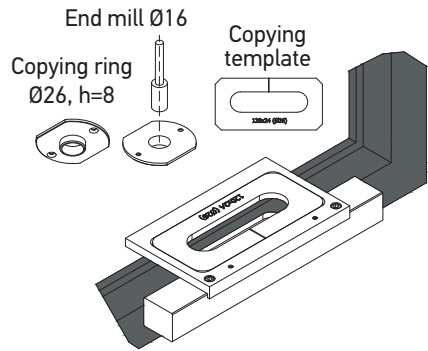
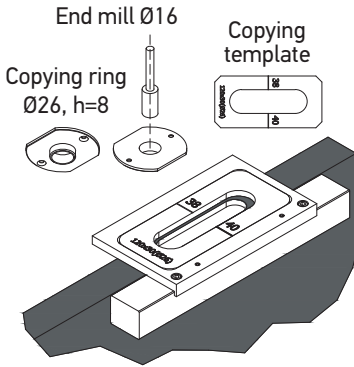
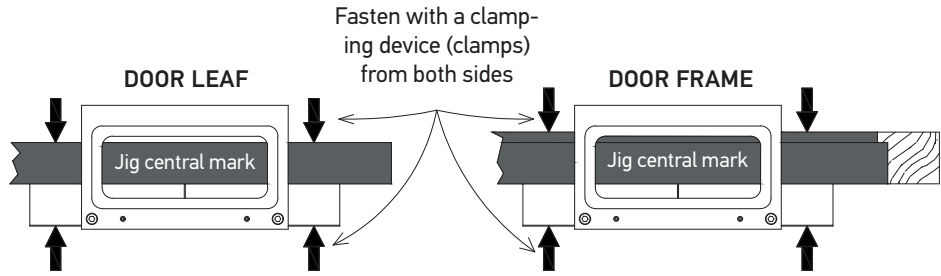

H, mm	
Door leaf	Door frame
30	21

A7226-03-N07 - milling jig, 30/24 mm

## INSTALLATION PROCEDURE

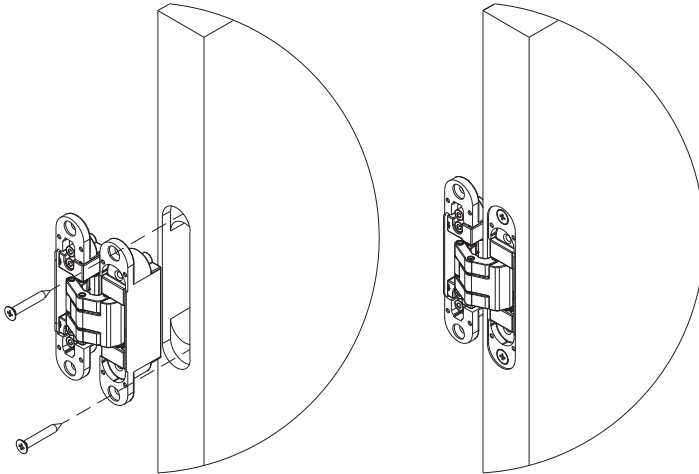

1. Install the hinges into the proper grooves on the door leaf, paying attention to the direction of opening (depth 30 mm).
2. Fix with screws  $\varnothing 5$  x min. 35.

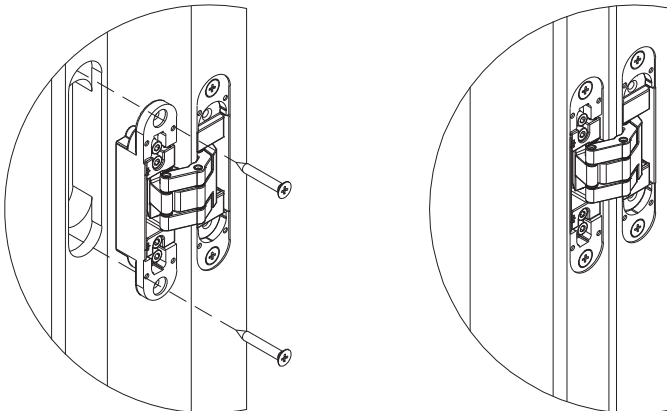

3. Install the door leaf on the door frame, inserting the hinges into the proper grooves (21 mm deep).
4. Fix with screws  $\varnothing 5$  x min. 25.

## MOUNTING PLATE D9001-24-N03

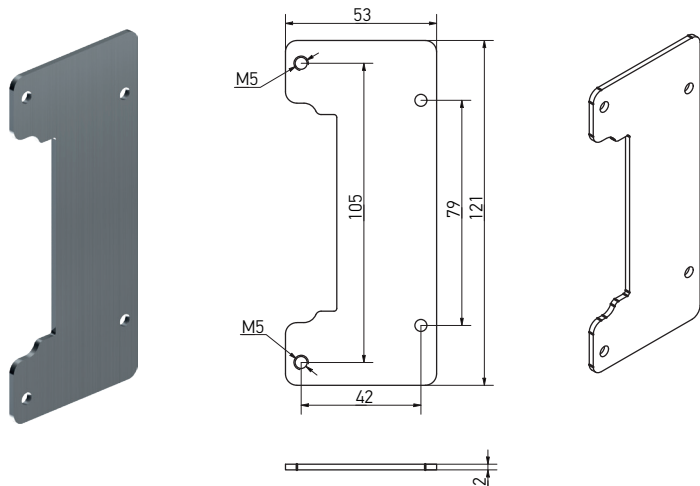

## INSTALLATION OF DECORATIVE COVERS

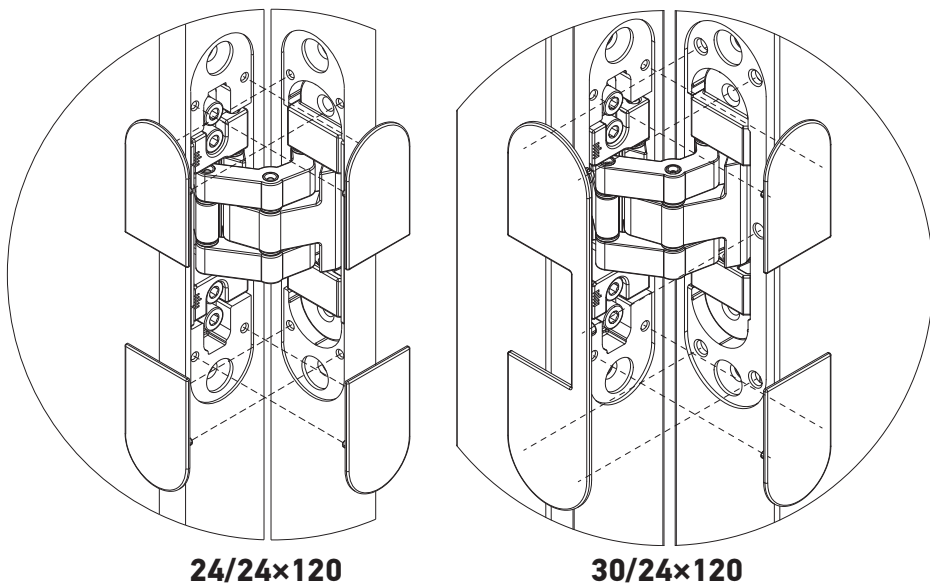

## VERTICAL ADJUSTMENT

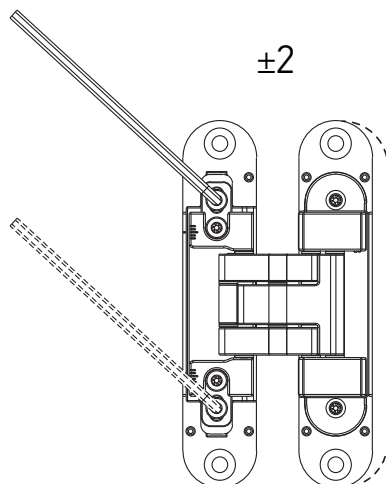

### Within $\pm 2$ mm.

Vertical adjustment is carried out on the part of the hinge installed in the door frame. To make the adjustment, it is necessary to loosen the two specified screws with a 3 mm hex key and lift up the door leaf to the required position. Using of a flat screwdriver is allowed, which can be inserted into the groove between the body and the adjustable part of the hinge and used as an additional lever. Holding the door leaf in the required position, tighten the fastening screws.

## HORIZONTAL ADJUSTMENT

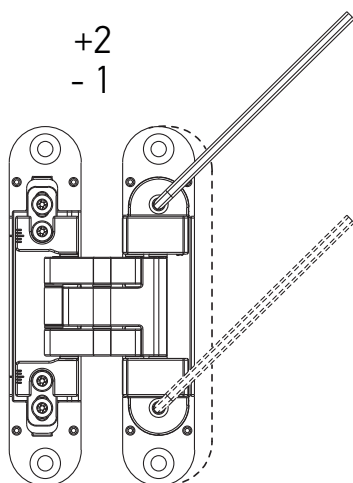

### Within $+2$ mm (toward the hinges) / $-1$ mm.

Horizontal adjustment is carried out on the part of the hinge installed in the door leaf. To make the adjustment, it is necessary to screw in or unscrew the two specified screws, using a 3 mm hex key, thereby setting the door leaf in the required position. It is not allowed to screw in or unscrew only one screw immediately to the extreme position, only sequential screwing.

## DEPTH ADJUSTMENT

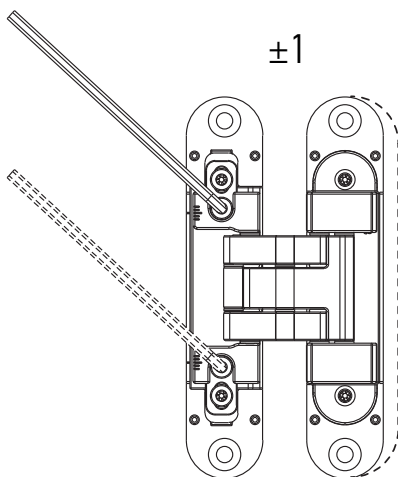

### **Within $\pm 1$ mm.**

Depth adjustment is carried out on the part of the hinge installed in the door frame. To make the adjustment, it is necessary to loosen the two specified screws, using a 3 mm hex key, and then install the door leaf in the required position. After adjustment, tighten the fastening screws.

## CERTIFICATES

Hinges were tested in independent certified laboratories and received documents certifying their quality. The quality of AXOR Arte Interior concealed door hinges is confirmed by the quality certificate of the International Institute of Window and Door Technologies ITB. You can download certificates on the website [axorindustry.com](http://axorindustry.com).

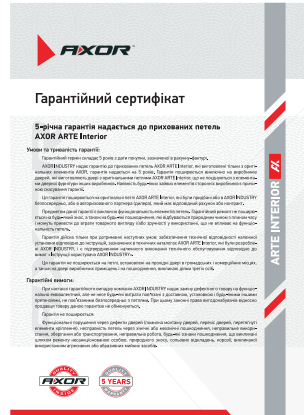
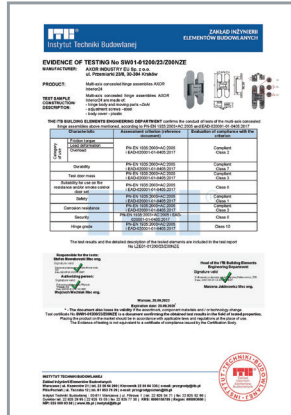

**Every month, 2% of the sales of concealed hinges is donated to the collection for mobile frontline hospitals**

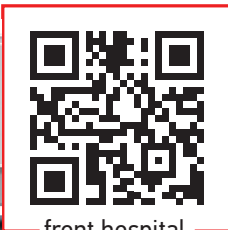

# AXOR



## AXOR INDUSTRY LLC

49041, Dnipro,  
Pratsi Ave., 32  
axorindustry.com



[instagram.com/axor\\_live](https://www.instagram.com/axor_live)



[facebook.com/AxorIndustry](https://www.facebook.com/AxorIndustry)



[infoaxor@axorindustry.com](mailto:infoaxor@axorindustry.com)



+38 067 55 42 777 Viber  
(for messages only)